

The valve that meets the market demand of the process industry

From the 1st of April 2007 Techno-G has taken over the Ball-Segment-Valve business from MPE Group GmbH Bolz-Summix, Wangen Germany. The experienced team around the Ball-Segment-Valve remains unchanged. Techno-G will provide you with a perfect product, supported by a professional project team starting with the inquiry, through delivery to installation and continued support through the BSV life.

The Ball-Segment-Valve has been developed to meet the unique process requirements of vacuum drying and pressurized process reactors. From experience gained in the field, it is now being supplied as a stand-alone component for a far broader range of applications. The valve seats are machined to very fine tolerances and this, combined with special bearings provides an excellent vacuum and pressure tight seal. The standard inflatable seal design will meet the demand of individual processes and product requirements.

Characteristics of the BSV

- Excellent reliability and long operating life
- Excellent vacuum and pressure tight properties
- No dead areas, sanitary design
- cGMP-conformity and CIP-able
- Full bore design, unobstructed product discharge
- Modular system
- Different sealing materials available



Standard specifications

- Valve size 150 – 450 mm (6" – 14")
- Flanges According to DIN, ANSI and as tri-clamp execution
- Material 1.4404, (316L), Hastelloy®, Alloy®, Duplex®, other stainless steels
- Inflatable seal EPDM, FFKM (Perlast®, Kalrez®), FKM, FVQM, FEPM + TFE/P
- Operation temp. -20°C – 150°C (-4°F – 302°F)
- Operation pressure -1 to +6 bar (90 Psig)
- Atex According Atex 94/9/EG

Markets

- Pharmaceuticals
- Chemicals
- Fine Chemicals, API
- Food
- Cosmetics
- Minerals
- Metals
- Others



Physical, process relevant bulk characteristics:

- Wide range of bulk densities
- Solvent-wet bulk materials or free flowing
- Crystalline and abrasive particles
- Hard and soft granulates
- Wide particle size spectrum
- Pasty, mushy or creamy products

Process applications:

- Outlet- and inlet valve for vacuum dryers
- Vacuum locks
- Outlet and Inlet valve for blender
- Discharge valve for centrifuges
- Outlet- and inlet valve for reactors

Reduction of unmixed passive zone

The larger the dimension X and the more the ball-segment (B) stands over the assembly flange (C), the unmixed passive zone in the process room, between the ball-segment (B) and the mixing agitator will be reduced to a minimum.

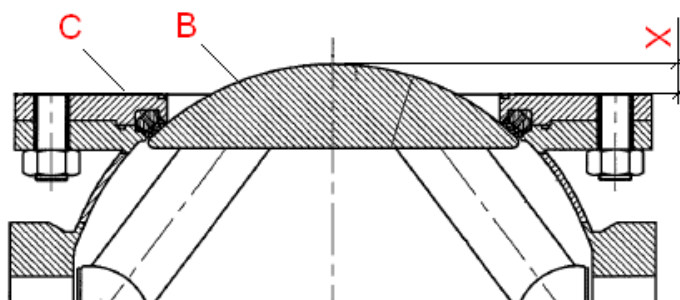

Full bore discharge design

Due to its totally unobstructed full bore design, a 90° turn of the ball-segment is required to move from the fully closed to fully open position, i.e. the ball-segment is entirely out of the product flow.



bottom view - full open position



bottom view - semi open position

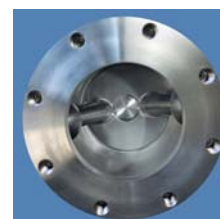

bottom view – closed position

Principle of the inflatable seal

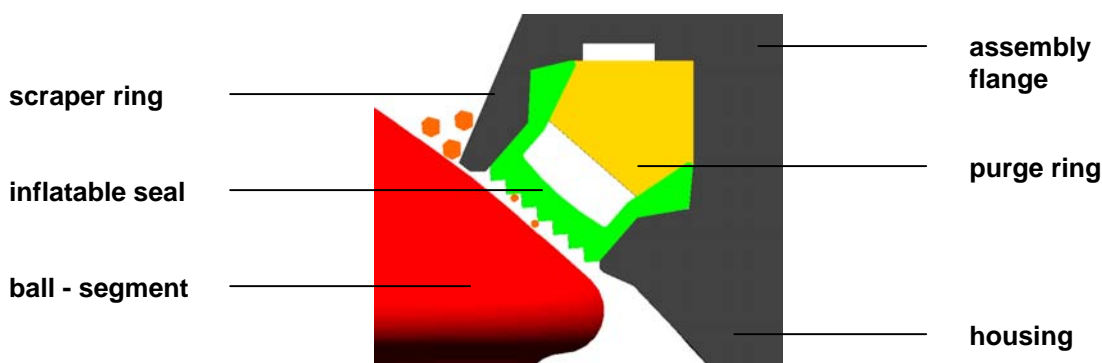

| Headquarters | Agency - Partner |
|--|--------------------------|
| Techno-G Solids Handling & Processing B.V. P.O. Box 62 7200 AB ZUTPHEN THE NETHERLANDS T: +31 (0) 575 593 177 F: +31 (0) 575 593 188 E: info@techno-g.com W: www.techno-g.com | here sticker or stamp |
| Germany: T: +49 (0) 4221 987 319 | |